

Sputtered Metal Coatings and UV Coatings— Working Together

By Don Parent

This article describes the recent merging of 3-dimensional metal coating and UV coating of plastic parts into a single in-line production process. An integrated, in-line approach to product finishing solves many of the most pressing manufacturing issues. The result is reduced costs, improved quality and simplified operation.

Today, many plastic products have metallic finishes. (Figure 1) While many of these metallic finishes have traditionally been applied through electroplating, vacuum metallizing (also known as Physical Vapor Deposition or PVD) is rapidly gaining favor due to its clean process and lower costs.

The Metallizing Market

Demand for decorative vacuum metallized coatings is increasing worldwide. There is a need for new

capacity and new process technology that will provide suppliers with a high quality product, while at the same time being environmentally friendly. Sputtered metal coatings combined with UV-cured basecoats and topcoats provide that solution. Sputtering emits no VOCs and produces no toxic chemicals, either directly or indirectly. It is a clean and dry process.

What is a PVD Sputtering?

PVD sputtering is a proven “metallizing” technology that’s been used in semiconductor, CD/DVD and consumer products manufacturing for many years. It produces a high-quality metal layer with excellent adhesion and film quality.

Sputtering is a vacuum process in which atoms from a solid metallic target are ejected from that target surface by bombardment with high-energy ions. (Figure 2) Those ejected

FIGURE 1

Metallic finishes on a variety of plastic products



FIGURE 2

Cathode operation schematic

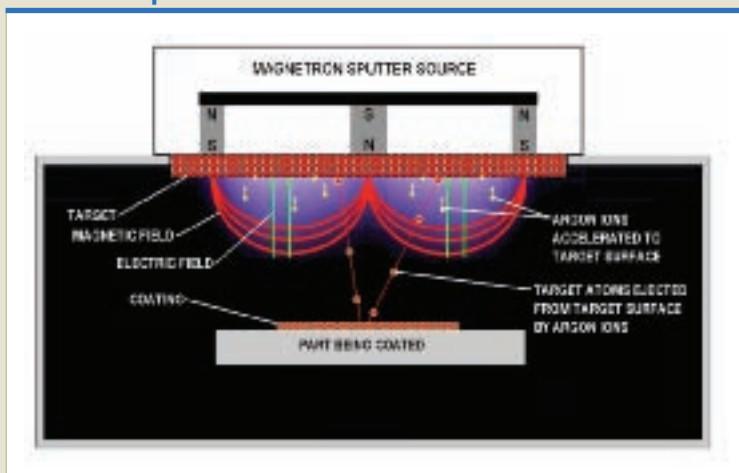

metal atoms travel unimpeded through the vacuum chamber and are deposited on the plastic substrate to be coated.

The target material can be any type of metal or metal alloy. Most plastic parts are decorated using aluminum. PVD sputtering is capable of depositing 100% aluminum as well as aluminum alloys with equal ease. Alloys are often used to provide corrosion resistance or to change the color or look of the sputtered metallic surface. For example, some copper alloys produce coatings that closely mimic the look of gold. Other metals or metal alloys such as stainless steel and chrome may also be used.

Base and Top Coatings for Metallized Plastic Surfaces

When a vacuum metallized layer is applied to a smooth plastic surface, that surface becomes reflective just light like a mirror. (Figure 3) Unless the mold and the resultant surface of the plastic part made in that mold are of extremely high quality, a UV-curable base coating is required to hide surface imperfections. The basecoating (applied prior to metallization) helps make the reflective metal coating look

flawless. Without the basecoating, any imperfection in the base plastic becomes very visible with a thin reflective metallic coating over it.

The vacuum deposited metal layer is approximately 100 nm thick or approximately the thickness of 1/1000th of a human hair. To protect this extremely thin layer of metal from scratching or abrasion, or to provide chemical resistance, a UV topcoating is applied after metallization for durability. The final surface

characteristics of the part may also be modified by the type of topcoating used. Coating choices might include matte and gloss finishes, various colors, and different textures that are usually dictated by the product designer.

Ultraviolet light-curable basecoatings and topcoatings are ideal for this process because they cure very quickly and require minimal floor space for the curing equipment. UV-curable basecoats and topcoats also provide high quality finishes with minimal or no VOC emissions. Water or solvent diluted UV-curable coatings contain very low levels of VOCs and provide an ideal surface upon which to deposit a metal coating as well as performing well as a protective top coat.

Solvent-free, 100% “solids” UV coatings contain virtually no VOCs. Since nothing is lost during the application process, solvent-free coatings may be reclaimed and re-used efficiently. The result is very high coating utilization rates and lower costs per part. And there are no costs associated with the management of VOC emissions and no VOC controls are required. Further, no solvent “flash-off” oven is needed to drive off the solvent. The result is a smaller

FIGURE 3

Basecoat, metal layer and topcoat

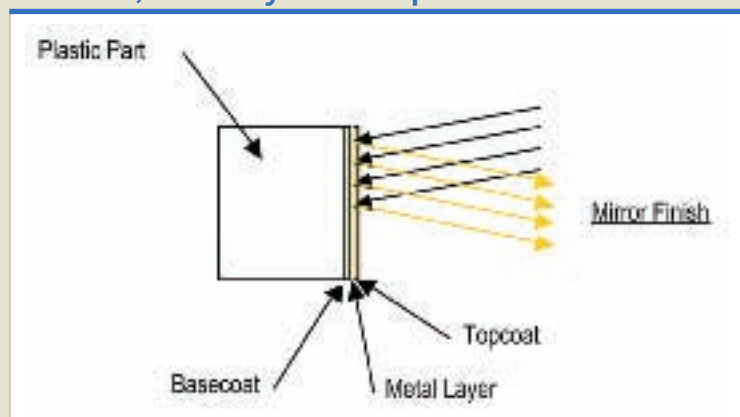

FIGURE 4

Integrated in-line process



overall system size, lower energy consumption and lower costs.

Batch vs. In-Line Metallizing

Vacuum metallizing and UV-cured basecoating and topcoating can be implemented as a complete process by either: (1) using the traditional approach (as separate processes) or (2) as an integrated in-line process.

(Figure 4) An integrated in-line process will provide, by far, the highest product quality at the lowest cost.

It is important to understand that basecoating and topcoating are by design “in-line” or continuous processes. A conveyor transports and rotates the plastic parts in a continuous manner in front of spray guns that apply the coating, and then

in front of drying or curing systems. In contrast, traditional vacuum metallizers are “batch” vacuum deposition chambers that cannot be readily integrated with a continuously moving conveyor. As a result, parts must be removed by hand from the (continuous) topcoating conveyor, loaded manually into the (batch) metallizer and then moved again by hand loading, back on the (continuous) conveyor for topcoating.

With batch metallization processes, “work-in-process” (WIP) part storage between each process is a necessary reality and results in a part “Vulnerability Window” of hours or even days. (Figure 5) In contrast, when basecoating, metallizing and topcoating are merged as a single in-line process, the “Vulnerability Window” can be as short as minutes with the result being reduced scrap and improved quality in addition to lower labor cost. (Figure 6)

The part “Vulnerability Window” can be described as the period of time between process steps when the parts are handled by operators, transferred from one fixture to another, or exposed to the surrounding environment where they might be contaminated with dust or damaged. For metallizing and coating, the “Vulnerability Window” starts when parts enter the basecoating line and ends when the topcoating is cured. With a true in-line process, the “Vulnerability Window” is minimized.

FIGURE 5

Batch metalization process

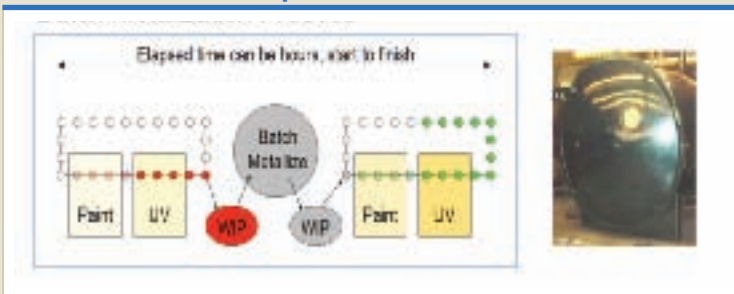

FIGURE 6

Integrated in-line metalization process

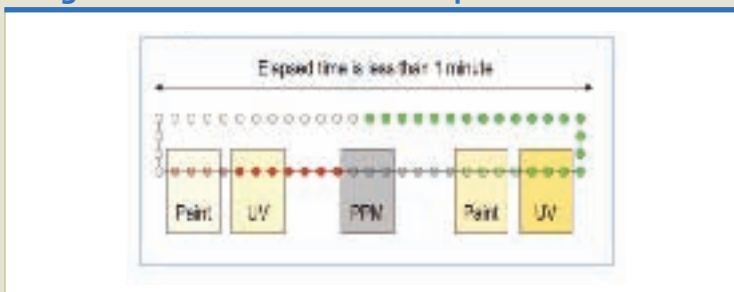

FIGURE 7

Integrated in-line coating system

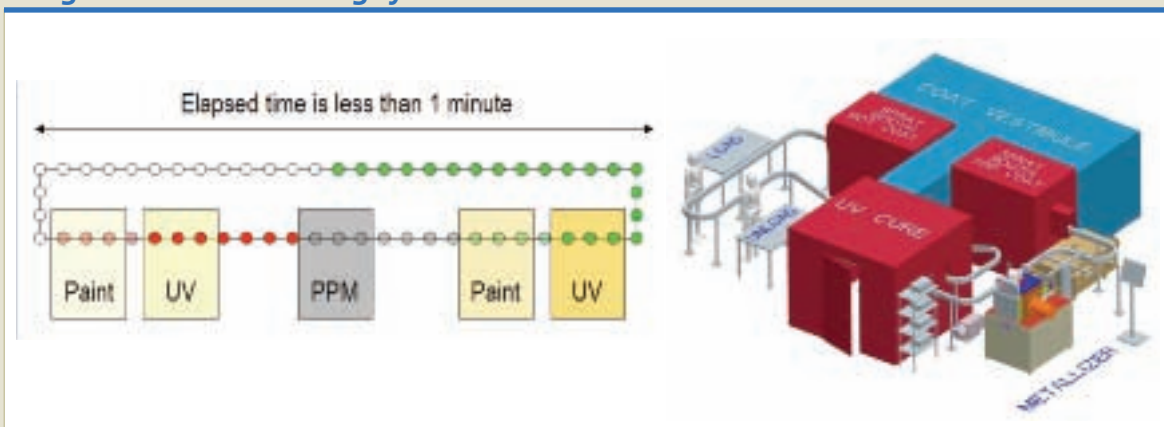
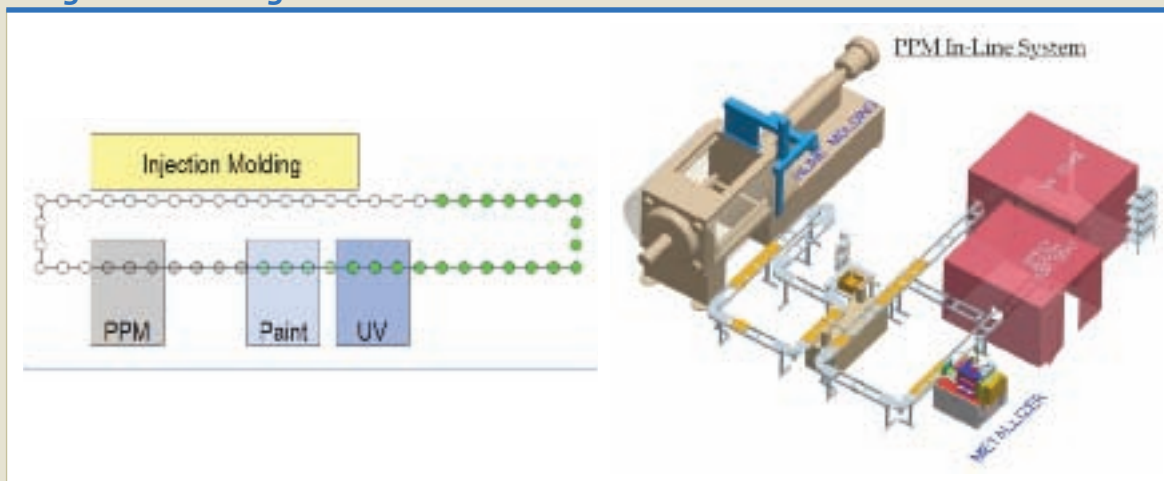

FIGURE 8

Integrated molding / no UV basecoat



An in-line metallizer transforms this process from “continuous-batch-continuous” into an uninterrupted true in-line process, eliminating the handling of parts between the coating and metallizing steps, thereby minimizing the part “Vulnerability Window.” In addition, an in-line metallizer minimizes labor costs and inventory, simplifies logistics, and reduces floor space required for the process.

**Implementation Example:
Single Chain-On-Edge**

An in-line metallizer integrates with a single Chain-On-Edge line and offers virtually no process latency or work-in-process. (Figure 7)

**Implementation Example:
Integrated Molding, No Basecoat**

Integrating injection molding with metallizing and topcoating

can eliminate basecoating. A fully integrated system is the result. (Figure 8)

Summary

In-line metallizing is a key enabling technology that solves the inherent problems of batch processing by facilitating interconnection of basecoating, metallizing and topcoating in a manner not previously possible.

All-new ILT490 belt radiometer.

The best just keeps getting better and better.

The **ILT490** now joins the **ILT400** with even more powerful features.

- ◆ Measurement spectrum matches industry standard IL390C (250-400nm)
- ◆ NIST - traceable calibration
- ◆ Built-in re-chargeable batteries (includes charger)
- ◆ Integrated exposure (J/cm²)
- ◆ Peak irradiance (W/cm²)
- ◆ Intensity profiling with auto-scale
- ◆ Baseline profile memory

Call **978-818-6180** or visit us on the Web at **intl-lighttech.com**.



10 Technology Drive
Peabody, MA 01960
978-818-6180
978-818-6181 fax
intl-lighttech.com



FIGURE 9

Tabular comparison of batch vs. in-line

Item	Batch	In-Line
Vulnerability window	2 hours or more	Minutes
Floor space	Spread out - large	Integrated - small
Approx cycle time	30 minutes	5 seconds
Process	Evaporation	Sputtering
Parts handling	Manual racks	Automated
Tooling	Large quantity due to WIP	Minimum quantity
Work-in-process	Large	Minimal
Logistics	Complex	Simple
Target change	Each cycle	2 weeks
Coating materials	Typically aluminum	Multiple

Plastic part metallizing was once a thriving U.S. industry using batch processing; however, that work is now done mostly offshore. Growing demand in Asia, combined with increasing shipping and energy costs and other factors, make local metallizing

once again an attractive business proposition. For this to succeed, however, metallizing and coating must be re-invented—it cannot be done the way it was done 30 years ago. In-line integration of basecoating, metallizing and topcoating is the solution.

Issues that are driving the shift back to “local” or in-house metallizing:

- Electroplating costs are increasing and have environmental challenges.
- RoHS (Restriction of Hazardous Substances) regulations are increasingly making electroplating a less attractive solution.
- Offshore manufacturing logistics are complex and costly.
- Rising fuel prices have dramatically increased shipping costs.
- Offshore manufacturing quality is inconsistent and difficult to control.
- Old batch metallizing processes are labor intensive. ▶

—Don Parent is president of D2 Inline Solutions, located in Scarborough, Maine.