

New Super-Portable UV-Curing Equipment

By George Wakalopoulos and Christy A. Dennis

Magnetic ballasts have limited the portability of mercury lamps for decades, while new electronic ballasts trade off weight against cost and simplicity. In this paper, we'll describe the lightest, most powerful and economical UV equipment in the world today for handheld and floor-curing applications. These systems work directly from standard 120/220-volt outlets without any heavy or costly power supplies. Lamps run at 300-500 watts/inch while curing widths range from 20 to 60 inches.

The purpose of this paper is two-fold—to introduce a new ballast technology, known as the “Z” technology, which is the key to super-portable UV-curing equipment, and to explain how this and other recent advancements are accelerating the emerging “Portable UV” curing industry.

Introduction

Almost all (97%) of the world's artificial lighting comes from mercury lamps,¹ mainly due to their efficiency and low cost. For the same reasons, mercury-arc lamps have been the staple of the UV-curing industry for nearly five decades.

Using heavy transformers or ballasts, these lamps have been limited to the factory setting, but are now slowly making their way into the field. Waterborne and dual-cure UV coating technologies, as well as environmental and economic concerns, are expanding the on-site, UV-curing market bathtubs, countertops, floors and walls are

being finished and re-finished with conventional UV-curing equipment.

However, recent economic and environmental concerns are now driving market demand for lighter, simpler and more affordable UV-curing equipment.

Within the next decade, the emerging portable UV-curing market is estimated to approach \$1 billion for equipment and up to \$20 billion² for coatings. Lower cost and portability will drive the equipment side of the market, while appearance, durability and applicability will dominate coatings development.

Background

In 1901, Peter Cooper Hewitt patented³ a new bright artificial light by passing electricity through mercury vapor gas discharges. To control his mercury lamp's power, he used Edison's incandescent bulb in series with the lamp as a current limit or ballast. Ballasts can be resistors, capacitors, inductors, transformers or a combination, thereof. They can also be electronic circuits in which the power to the lamp is controlled by high-frequency switching techniques.

Today, the most widely used and heaviest part of the ballast is the transformer. Fluorescent lamps use small ballasts due to their low power, while typical UV-curing lamps use hundreds of watts per inch requiring high-power ballasts from 1 to 40 kilowatts (kW).

Magnetic ballasts use iron cores. Their weight in pounds is approximately = $12x + 40$, where x is

FIGURE 1

Typical magnetic ballast

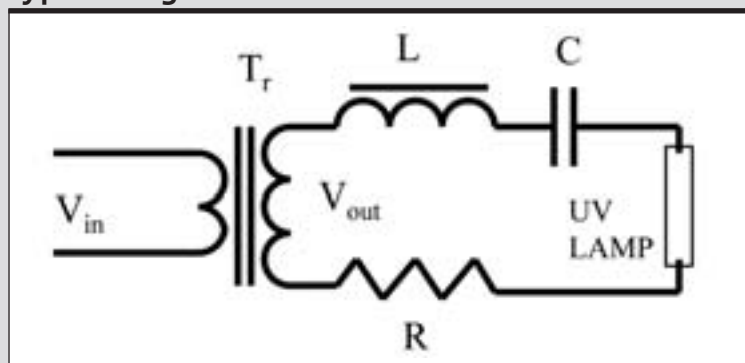

the power in kW. The most common power source is the 120-volt, 15-amp residential outlet delivering a maximum of 1.8 kW. Other outlets deliver 220 volts at 15, 20, 30 and 50 amps delivering 3.3 kW, 4.4kW, 6.6 kW and 11 kW, respectively. Typical UV lamps operating at these power levels require magnetic ballasts weighing 62, 80, 93, 120 and 172 pounds, respectively. The entire system, however, can weigh more.

Electronic ballasts offer an alternative to the heavy magnetic ballast. Compact electronic ballasts with power levels up to 3.5 kW weigh less than 15 pounds and are readily available in the marketplace, but their cost is significantly higher than their magnetic counterparts. A third option uses resonant or hybrid technologies that are lower in cost and weight than the electronic ballast.

Conventional Ballast Technologies

Discharge Lamp Ballast

The voltage across a gas discharge increases with distance and gas pressure.⁴ Typical mercury lamps contain low-pressure (Argon) gas with a small amount of mercury. Current passing through the lamp increases its temperature, evaporating the mercury and causing its pressure to rise. This

results in an increase in voltage across the lamp. The maximum lamp voltage occurs when all the mercury is in the vapor state and/or when the lamp is at its operating temperature of 600-900° C.

Magnetic Ballast

A simplified equivalent circuit of a magnetic ballast for a mercury lamp is shown in Figure 1. A transformer (T_r) steps up the input voltage to approximately twice the lamp voltage to ignite the lamp. The inductance (L) is part of the transformer.

The lamp current (I) is limited by the circuit impedance $Z = (R^2 + (X_L - X_C))^{0.5}$ where $X_L = 2\pi fL$ and $X_C = 1/2\pi fC$. C is the capacitance, R is the resistance

of the wire in the circuit and f is the line frequency (60 Hz).

The circuit has a resonance at $X_L = X_C$ where the current peaks. The current or power of the lamp varies by changing the capacitor value C . When the lamp reaches its operating voltage, a fan keeps the lamp from overheating. At this point, a constant current is maintained with an autotransformer or constant wattage ballast with series capacitor. Power (lamp voltage times current) is maintained constant even with voltage and current variations resulting from input voltage variations or lamp aging.

Resistive Ballast Theory

Unlike the magnetic ballast, the current in the circuit of the resistive ballast drops as the lamp voltage increases. For a constant resistance (R), the steady state voltage of the lamp depends on its cooling parameters. Thus, the cooling provided by forced convection from the fan is an important parameter in resistive ballasts and in combination with the series resistance defines the prime control parameters that determine the lamp's operating point on the load line.

Figure 3 illustrates the lamp's voltage-current relationship as a

FIGURE 2

Basic resistive ballast

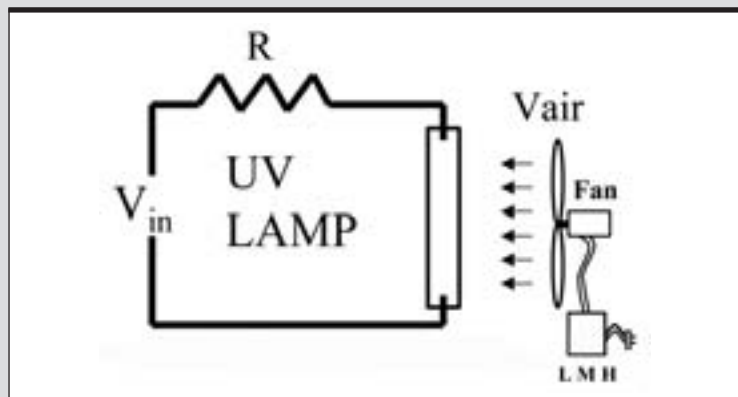
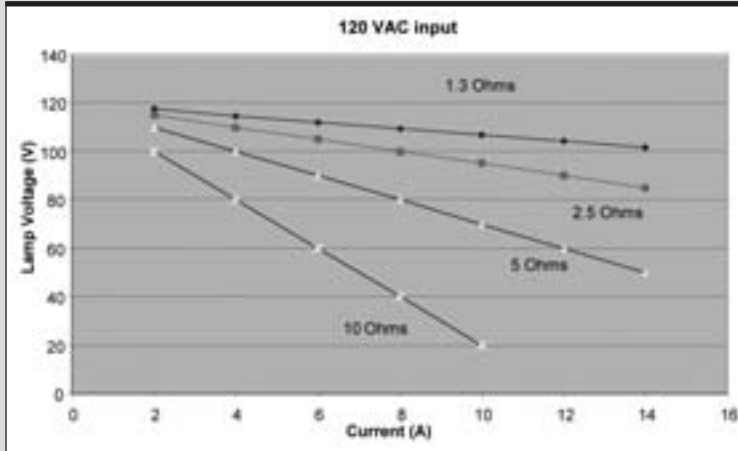

FIGURE 3

V-I characteristics of UV lamp



function of ballast resistance at an input voltage of 120 volts AC. For a fixed resistance, the lamp's operating point cannot be easily determined because the lamp's voltage depends on the amount of mercury evaporated, which depends on the lamp's temperature. With forced-air cooling, the lamp will reach a voltage determined by its input power balanced by its power loss from radiative and convective cooling. Unlike a magnetic ballast in which the lamp voltage reaches a fixed value when the mercury is completely evaporated, a resistive ballast becomes more efficient when the lamp's voltage approaches the input voltage. Should the lamp's voltage exceed the input voltage, it extinguishes.

Lamp Voltage

A mercury lamp with a series resistance (R) connected to a voltage (V_m), has an initial voltage drop of approximately 15 volts and its current increases to $(V_m - 15)/R$. This voltage drop is associated with the energy required to emit electrons from the metal electrodes into the gas. The voltage⁵ (V/cm) of the tube depends on the amount of mercury evaporated and

is $V_t = m^{7/12} d^{-3/2}$, where m is the amount of mercury (mg/cm) and d is the tube diameter (cm). The vapor pressure of mercury is a function of temperature⁶ (°K) and can be expressed as $P = 7.58e^{-1} T + 3.9e^{-3} T^2 + 4.8 e^{-6} T^3$, where P is the pressure in kilo-Pascals (kPa). Equating the pressure from the ideal gas law, $P = n R T / V_o$ with the mercury vapor pressure from above and substituting for the amount of mercury (moles), the lamp's steady

state temperature (7.5 cm lamp, d=2cm) as a function of total lamp voltage (V) can be expressed as:

$$T (°K) = 6 V + 390 \text{ for } V > 15 \quad (1)$$

Where P is pressure in kPa, n is the amount of evaporated mercury in moles, V_o is the volume of the lamp in liters, R is the gas constant (8.31 kPa L/K mol). The lamp's steady state envelope temperature can also be determined from power balance considerations as follows.

Lamp Temperature

To determine the lamp's operating temperature we look at the power loss from⁷

$$Q_{input} = Q_{convection} + Q_{radiation-lamp} + Q_{ballast} + Q_{radiation-arc} \quad (2)$$

Where $Q_{Convection}$ and $Q_{radiation-lamp}$ is the power of the lamp lost by convection and radiation, respectively, in watts. The convective heat loss depends on the Nusselt number (Nu) as:

$$Q_{convection} = Nu k A (T_2 - T_1) / D \quad (3)$$

Where A is the lamp's surface area, k is the thermal conductivity of air, T_s is the lamp's surface temperature

FIGURE 4

V-I characteristics for 7.5 cm mercury lamp

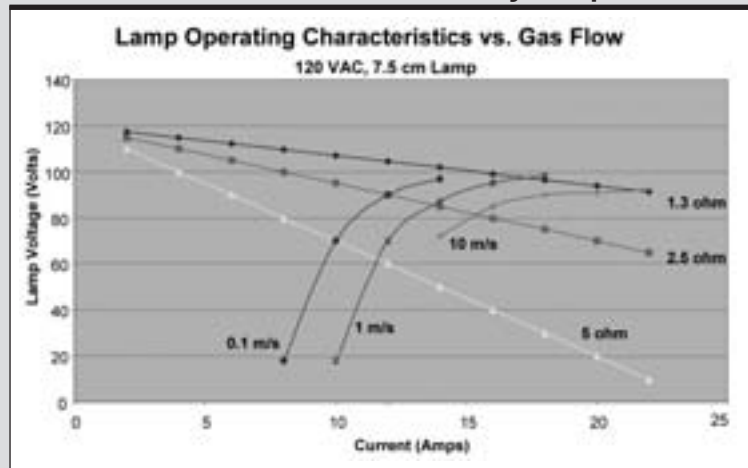

(°C)⁸ and T₁ is the surrounding air temperature (°C) and D is the lamp's diameter. For forced convection, the Nusselt number is:

$$N_{uf} = 0.3 + 0.62 R_{ed}^{1/2} Pr^{1/3} \left((1 + (0.4/Pr)^{2/3})^{1/4} \right)^{-1} \left((1 + (R_{ed}/282,200)^{5/8})^{4/5} \right) \quad (4)$$

Where R_{ed} is the Reynold number and Pr is the Prandtl number. The power lost by radiation is:

$$Q_{radiation} = \epsilon A \sigma ((T_2)^4 - (T_1)^4) \quad (5)$$

Where ϵ is the emissivity of quartz (0.93)⁹, A is the surface area, and σ is the Stefan-Boltzmann constant. Assuming T₁ = 300°K and that the non-radiative loss heating the quartz lamp is nearly equal¹⁰ to 1/3 of the input power (V_i I). By combining 2, 3, 4 and 5, and the ballast power (R I²) and substituting 1, for a 7.5 cm lamp:

$$V_i I = A (6 V + 112) + B ((6V + 390)^4 - 300^4) + R I^2 + 2 V_i I / 3 \quad (6)$$

Where A = Nu k A/D, B = $\epsilon A \sigma$, R = series resistance. This can be solved numerically for voltage (V) as a function of current (I). The lamp's steady state V-I characteristics can now be determined by gas flow and external circuit parameters. By combining this with the load lines in Figure 3, we can determine the lamp's operating point for a given gas flow and load resistance.

Figure 4 shows steady-state lamp operating points as a function of resistance and gas flow. The straight lines from top to bottom are the ballast resistance curves from Figure 3. The intersection of these curves with the V-I characteristics of the mercury discharge indicates the lamp's operating points at a gas flow of 0.1, 1, and 10 m/sec. It is evident that for these points dV/dI + R > 0 and thus represent a net positive impedance¹¹ (i.e., the overall impedance is positive and, therefore, implies a stable operating point.) The final lamp's

FIGURE 5

Simple variable resistive ballast

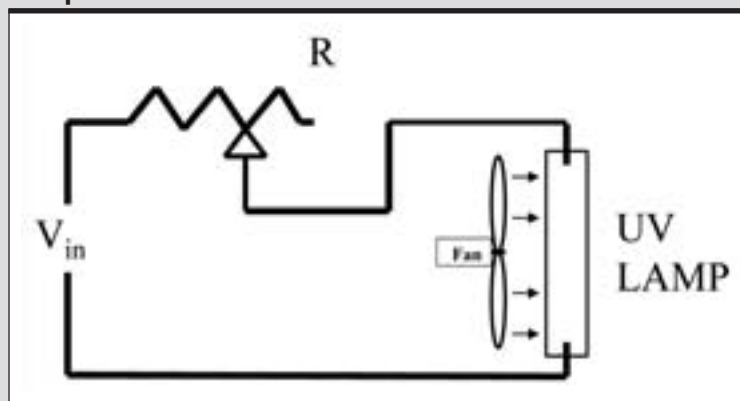

voltage can now be tuned by adjusting gas-cooling parameters and resistance.

Ballast Design

To maintain a constant current with a resistor requires a variable resistance ballast as shown in Figure 5. A simple method is to reduce the resistance where the ballast power is halved (i.e., at lamp-voltage levels calculated not to exceed 50% maximum ballast power limits). By expressing lamp voltage as percentage of input voltage $V_L = \% V_i / 100$, $\Delta V = V_i - V_L$, $I = \Delta V / R$, $P_B = I^2 R = \Delta V^2 / R$, where P_B is the ballast power and ΔV is the difference between input and lamp voltage. R is the ballast resistance. To limit ballast power to 50% of the previous value, the resistance is reduced as follows:

$$\%V_2 = (100 + \%V_1)/2 \quad (7)$$

Where %V₂ is the lamp's next switching voltage and %V₁ is the previous voltage. The voltage levels for a 120-volt input lamp are shown in Table 1.

If the resistance R is known; P_B = V_i² (100-%)² / (100² R), P_L = V_i² % (100-%) / (100² R), and I = V_i (100-%) / (100 R), where P_L is lamp power and I is the current in amperes. For a ballast resistance of 10 ohms, the lamp power for the example above is 158, 709, 985, 1,119 watts, respectively. It is interesting to note that the lamp's overall electrical efficiency P_L / (P_L + P_B) is equal to the lamp's voltage in percent of input voltage equal to 89.1% as shown in Table 1.

TABLE 1

Voltage levels for 120-volt input lamp

%	Voltage
12.5	15
56.3	67.5
78.1	93.8
89.1	106.9

FIGURE 6

Lamp and ballast power, voltage, ballast resistance, for I = 12 amps

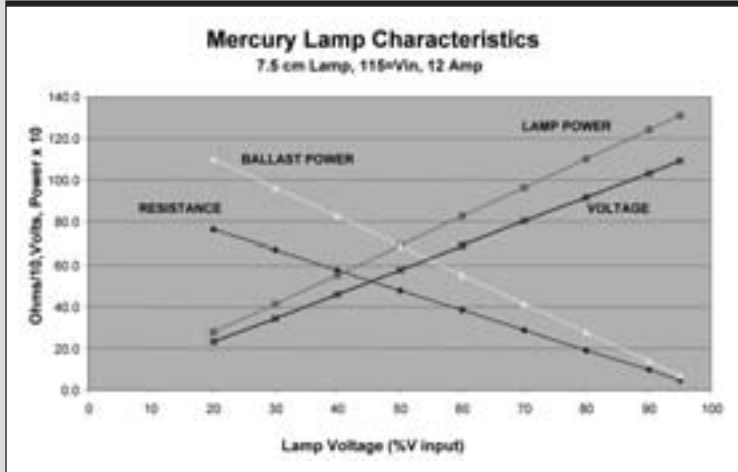

Figure 6 illustrates the lamp's characteristics with a constant 12-amp current level. For this example, the resistance of the ballast is decreased linearly by electronic means.

As shown, the lamp's efficiency is low during warmup but is equal to or exceeds that of a magnetic ballast (~85%) at its operating temperature. Since the resistance can be modified by a variety of methods, the cost of the ballast can also vary depending on the product's design.

Applications of "Z" Technology

To provide practical applications for resistive-ballasted UV lamps, small reflectors¹² and high-power resistors are required, as is a means to change their resistance as the lamp warms up. This is accomplished with air-cooled nichrome, wire-heating elements and semiconductor switching techniques.

Handheld Unit

Figure 8 shows a conceptual handheld UV system with a self-contained ballast¹³ that operates at 120-VAC input, 12 amps. This unit can replace large bulky power supplies that

are less practical on the job site. The self-ballasting unit can also be designed to operate directly from a household power outlet with up to a 100-foot extension cord for remote applications. A key concern with the handheld unit is safety. Proper labeling, education and other mechanical or electro-optical

means must be used to avoid exposure of UV radiation on the eyes and skin.

The handheld unit is ideal for curing countertops, bathtubs, corners, patchwork, surfboards, silkscreen inks and in laboratories for UV-coating development.

UV Floor-Curing Machine

Inherent in resistive ballasting is the use of short lamps (less than six inches) that can be operated from either 120- or 220-volt outlets without transformers. To compensate for the small lamp size, but still be able to cure large areas, the concept of rotating lamps¹⁴ has been devised. Figure 9 (a,b) shows two conceptual models of floor machines. Both house two, three-inch lamps that rotate from a suspended shaft with casters in the middle. Their peak power level is extremely high because multikilowatt power is applied across three-inch lamps. Unlike straight, long UV lamps, these spinning lamps can be left in an idle mode for a longer period of time without burning or damaging floors.

FIGURE 7

Illustration of the difference in weight and size of a 2 kW magnetic versus a resistive ballast

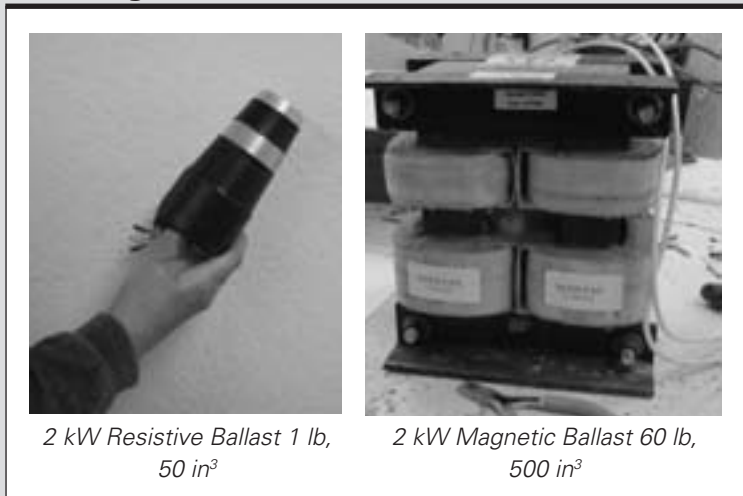

FIGURE 8

Conceptual handheld UV system



The machine is designed to move in an omni-directional motion for ease-of-use and a more consistent cure path.

Alternative Machine Options

The floor machine can also be designed to connect to one another, as shown in Figure 10, to achieve a cure path of up to 60 inches. This is especially crucial in commercial applications where noisy generators are not allowed or 220-volt outlets

FIGURE 9

Conceptual 220-volt rotating UV lamp floor-curing machines shown with and without self-contained ballast

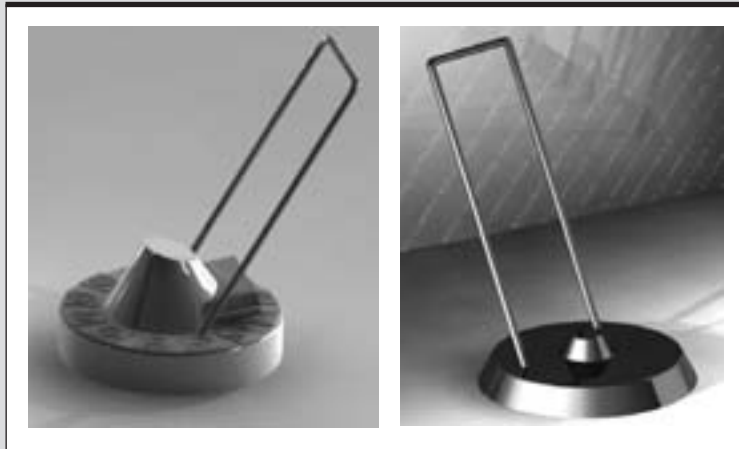

are not available, such as in hospitals, shopping malls or restaurants. Each machine must be plugged into a separate 120-volt outlet with a 15-amp

breaker. Each is connected to an extension cord up to 100 feet long.

Future designs may include a remote-controlled machine that can be programmed to cure open areas similar to the vacuum cleaning machines now available for residential applications.

Similar to the UV Floor Machine with its resistive ballast, smaller second-generation “smart” equipment will have applications in markets not yet envisioned.

The rotational concept can also be adapted to many other machine designs, including handheld units to cure 3-D objects such as furniture, decorative rocks and bathtubs. This technology can also assist in the future development of other coating applications to enhance increased productivity while lowering costs of the overall UV-curing industry.

Rotary Lamp Variables

As previously established, super portability implies short lamps, therefore it's important to investigate the curing pattern of a two-lamp system. With two lamps rotating on a 20-inch diameter spindle, the operator

FIGURE 10

Three connected 120-volt rotating lamp machines with effective curing width of 60 inches



FIGURE 11

Spatial cure pattern of a two, 3-inch lamp machine with forward speed of 40-ft/min, 30 RPM 10-inch radius machine rotation

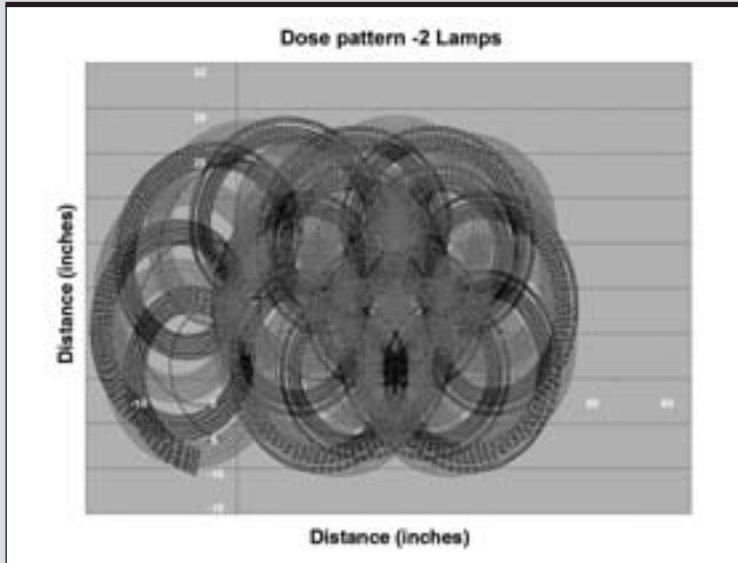

can move the system at a suitable speed and also rotate the machine at a given radius. The pattern of a point (r) on the lamp then follows the equation of a double trochoid:

$$x = vt - r \sin(2\pi\theta t) - R \sin(2\pi\phi t) \quad (8)$$

$$y = R - r \cos(2\pi\theta t) - R \cos(2\pi\phi t)$$

Where r = any point on the lamp, R = Machine radius, θ = the rotations per minute of the lamps, ϕ = the rotation per minute of the machine, v = forward speed of operator, and t = time in seconds.

The spatial cure pattern of a two, three-inch lamp, 20-inch diameter machine with a forward speed of 40-ft/min, 200 RPM lamp rotation and 30 RPM 10-inch radius machine rotation is achieved as shown in Figure 11. While the illustration shows some uncured areas, a skilled operator will ultimately cover the entire floor similar to the pattern of a rotary sanding machine.

UV Safety

When the laser was invented in 1960, reporters called it the “death ray.” Today, battery-operated pointing

lasers are widely used and accidental exposure to eyes is minimized by proper labeling, handling and training.

Just as with lasers, portable UV-curing equipment must be properly marked with safety labels to minimize the possibility of accidental exposure to eyes and skin. Under normal operating conditions, exposure from reflections of properly shielded portable UV equipment can be minimized and appropriate eye and skin protection makes portable curing units safe for long-term use.

Table 2 shows the UV output level of direct and reflected UV light from a 120-volt, 1,000-watt, three-inch handheld and 3 kW floor machine, measured with a UVA meter in Watts/m².

The afternoon sun measures 15.5 W/m² in the UVA region. Therefore, at normal operating distances, the exposure levels shown in Table 2 indicate UV doses are 50 and 1,000 times less than the sun’s exposure from the reflections of the handheld and floor machine, respectively. Just as people wear sunglasses and apply sunscreen while outdoor in the sun, the same precautions should be followed when working with UV lamps.

Conclusion

We have shown that the portable UV-curing market has tremendous potential for growth in field applications. In order to make this market practical, portable UV equipment must be light, powerful and economical.

TABLE 2

UV light exposure

Handheld		20"-diameter floor machine	
Direct	Reflected	Reflected	
1cm	200cm	100cm	2cm
10,000	1.5	0.3	0.01

We have shown that it is feasible to operate mercury lamps with resistive ballasts, making UV-curing equipment significantly more portable and less costly than other UV-curing technologies available on the market today. Although resistive ballasts consume more power than the lamp during warmup, efficiencies equal to or greater than magnetic ballasts are possible.

Exposure from reflections of properly shielded, portable UV equipment can be minimized. By training, proper use, labeling and appropriate eye and skin protection, portable UV-curing units have been shown to be safe for long-term use.

Reliability and lifetime numbers of this new emerging technology compared to magnetic and electronic ballast technology is still premature, but with the anticipated high growth of the portable, UV-curing market, we will be able to compare this "Super-Portable" UV-curing technology to its counterparts within a few years.

In conclusion, "Super-Portable" UV equipment is defined as that which can be carried by one person (< 35 lb. per hand) for floor machines and less than two pounds for handheld units. ■

References

1. The International Energy Association (www.iea.org).
2. Private communications with M. Satoh, Marubeni Techno-Systems America Corporation.
3. Electric Lamp, Peter Cooper Hewitt, U.S. Patent, September 17, 1901.
4. J.J. Thompson and G.P. Thompson, "Conduction of Electricity through Gases," Vol 2, p. 362.
5. W. Elenbaas, *Physica*, 1, 211, 673, 1934; 2, 45, 169, 1934. G. Heller, *Physics*, 6, 389, 1935.
6. Handbook of Chemistry and Physics, Forty-Fourth Edition, 2426, 1962.
7. Estimating the Performance of Ambient Conditions and Aging On The Performance of UVGI Air Cleaners, J. Lau, W. Bahnfleth, and J. Freihaut, 2002.
8. Study of a Mercury Discharge Plasma During Initial Warmup, N. L. Bashlov, V. M. Milenin, G. Yu. Panasyuk, and N. A. Timofeev, *Zh. Tekh.* 65, 26-37 (March 1995).
9. J.D. Cobine, *Gaseous Conductors*, McGraw-Hill, 1941.
10. Phillips, Roger, *Sources and Applications of Ultraviolet Radiation*, Academic Press, London, 1983.
11. W. Kaufmann, *Ann. D. Physic*, 2, 158, 1900.
12. Gas-Cooled Reflector Structure for Axial lamp Tubes, George Wakalopoulos, Patent Application, Filed April 30, 2008.
13. Handheld, High-Power UV Lamp, George Wakalopoulos, Patent Application, Filed 09/11/08, Allowed 12/15/09.
14. Jet-Driven Rotating Ultraviolet Lamps for Curing Floor Coatings, George Wakalopoulos, Patent Application, Filed 06/05/09.

—George Wakalopoulos is
CEO/president and Christy A.
Dennis is PR and media director
with Adastra Technologies, Inc.,
in Torrance, Calif.

ODE TO UV (PART 1)

Our first UV Prayer appeared in the year two thousand and two.
Did you see the "light" and change your process control view?
Time flies and a lot has changed with every passing year.
Tell me, have you kept up or is UV something you still fear?
Goodbye "dose - it's now called "radiant energy density".
Hello "irradiance" - what happened to the word "intensity"?
At the end of the day when production has ground to a halt,
Do you jump on Facebook and say it's still the chemist's fault?
New types of power supplies, and now UV LEDs.
Can someone help me sort these things out.... pretty please?

For straight answers without having to ask "pretty please" call EIT. We have the products, the experience and staff - both in the field and in-house - to help you understand, document, achieve and maintain control of your UV process.



703-478-0700
www.eitinc.com
uv@eitinc.com